

# Wide Band PD Series

O/E CONVERTER



Please read this manual carefully before use

### Model

SPD-3

SPD-4

Gravizon INC

[https://www.graviton.co.jp/index\\_En.html](https://www.graviton.co.jp/index_En.html)

Page 1

### Contents of this package

The contents of this package are listed below.

Please contact immediately the shop you purchased this product, if there is any missing items found.

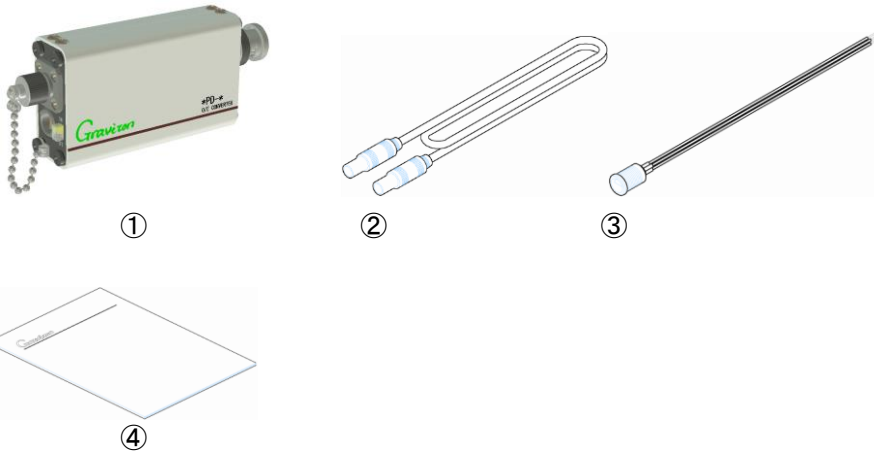

- ① O/E converter
- ② Power Cable Assembly
- ③ Auxiliary Power Connector
- ④ User's Manual (this manual)

◇Please keep original packaging, in case of re-shipping.

Page 3

### Introduction

Thank you for purchasing PD Series O/E Converter.

PD Series is Optical to Electric signal converter and has following feature.

- SPD-3 : 500mV/mW SPD-4 : 300mV/mW (@ 850nm Wave Length, 50/125 GI Fiber)
- Wide Frequency Range  
DC~2000MHz Flatness +0.5 -3.0[dB electrical] SPD-3  
DC~3000MHz Flatness+0.5 -3.0[dB electrical] SPD-4
- Standard FC optical connector  
(Optional SC, F05, SMA, and ST connector are also available.)
- Standard BNC plug  
Able to connect directly to an oscilloscope, a spectrum analyzer etc.
- Able to get DC power from instruments through included Power Cable Assembly.  
It is not guaranteed that power cable corresponds to all instruments.
- Able to use for instrumentation of lightwave products, optical links or other various applications.

Please read this user's manual carefully and use it appropriately according to this manual, will make this product useful for development of light wave equipments, lightwave communication converter or other various applications.

- ◇Do not re-produce or re-publishing a part or all this manual without written permission from Gravizon Inc.
- ◇This manual is subject to change without notice.
- ◇Please follow exporting regulations/rules in individual countries when exporting this product to other countries.

Page 2

### Front and rear panel view



- ① Power switch  
This switch is for controlling power. Please on/off this switch after connecting power cable assembly to power connector (2) also keep this switch off when not in use.
- ② Power input connector  
The power can be supplied from probe power connector that equipped with an instrument through the Power Cable Assembly. Or, alternately, external regulated power supply (not included) can be used through the Auxiliary Power Connector. Power supply voltage for PD series is  $\pm 15[V]$ . **Applying over and/or wrong polarity may cause permanent damage.** Please refer the specification in page 7 for current consumption and page 5 for the detail of the power connection.
- ③ Optical signal input connector  
Light signal supplied through this FC connector is up to  $-1[dBm]$  for SPD-3 and up to  $+1[dBm]$  for SPD-4. **Please do not apply 10dBm or higher light signal. It may cause permanent damage.**
- ④ Electrical signal output connector  
50[Ω] input impedance with wide frequency range instruments is suitable to observe light signal. Recommended to use wider frequency range instruments to withdraw full spec. (DC~2000MHz SPD-3, DC~3000MHz SPD-4)

Page 4

## Set up

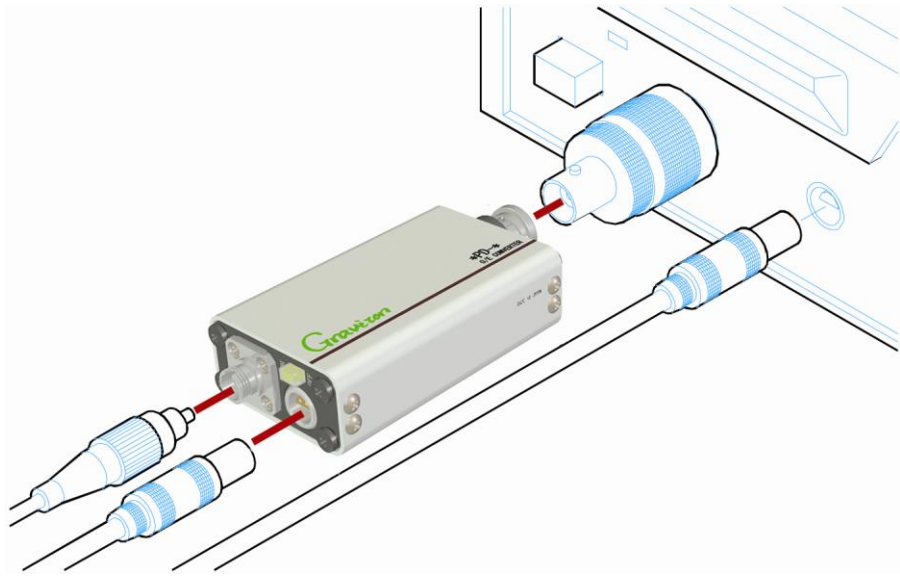

1. First of all, connect the O/E converter to input connector of an instrument. Conversion connector may be required, if the instrument has no BNC jack.
2. Confirm power switch on the O/E converter is off then connect Power Cable Assembly supplied. Other side of the Power Cable can be connected to the instrument, if probe power connector is equipped. Please refer page 6 for connecting external power supply, if the instrument has no probe power connector.
3. Turn on the power switch.
4. Connect fiber connector to the O/E converter and adjust voltage and sweep time of the instrument observe the light signal. Also make sure 50[Ω] impedance is selected on the instrument.

Page 5

## Specifications

Item	Test Condition	SPD-3	SPD-4
OE Device		Si PIN PD	Si PIN PD
Peak Sensitivity Wavelength		700nm	700nm
Wavelength Range	More than 1/5 of peak sens.	380nm ~ 950nm	380nm ~ 950nm
Conversion Gain	50GI Fiber	500mV/mW @850nm	300mV/mW @850nm
Acceptable Core Diameter		Less than 0.5mm	Less than 0.5mm
Acceptable Fiber NA		Less than 0.25	Less than 0.25
Frequency Bandwidth	-3dB electrical	DC~2.0GHz	DC~3.0GHz
Maximum Optical Power for Proper Signal Output	400mV Out	-1dBm @850nm	+1dBm @850nm
Wideband Noise Voltage	Up to 12.4GHz	Less than 1.5mVrms	Less than 1.8mVrms
Noise Equivalent Power	850nm	Less than -25.2dBm	Less than -22.4dBm
Output Offset Voltage	No Input Signal	Within +/- 0.5mV	Within +/- 0.5mV
Output Impedance		50ohms	50ohms
Input Optical Connector		FC	FC
Output Coax Connector		BNC Plug	BNC Plug
Supply Voltage		+/-15V DC	+/-15V DC
Supply Current		+150mA/-50mA	+150mA/-50mA
Physical Dimension[mm]		103x44x21	103x44x21
Weight[g]		130	130
Operational Temperature	+5[°C]~+35[°C]	Storage temperature -20[°C]~+50[°C]	

(This specifications are subject to change without notice.)

Page 7

## Connecting External Power Supply

1. An external power supply is necessary, if an instrument going to use has no probe power output. The requirements for the power supply are regulated  $\pm 15[V]$   $\pm 5[\%]$  and capable of supplying more than 150[mA] current with low ripple and noise. And connect as following figure.

Wrong power supply connection may cause permanent damage on the O/E converter. Please make sure the connection as **RED Cable for Positive terminal**, **Black Cable for Ground Terminal** and **Blue Cable for Negative Terminal**.

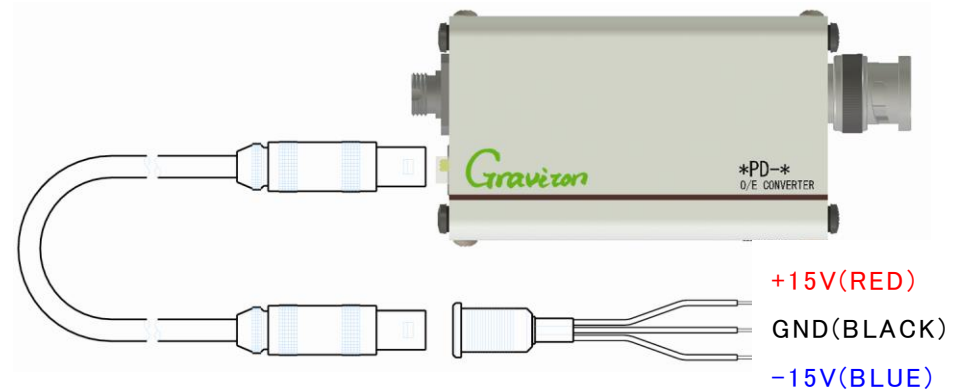

2. Panel cutout size is as following to mount the Auxiliary Power Connector on a panel, if necessary. Maximum allowable thickness of the panel is 5mm.

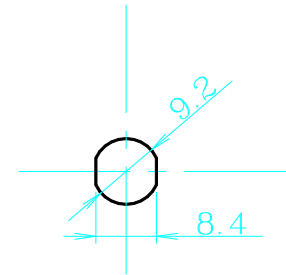

Page 6

## The Spectral Sensitivity curve of SPD-3 & SPD-4

(Reference point is 1 at 850nm)

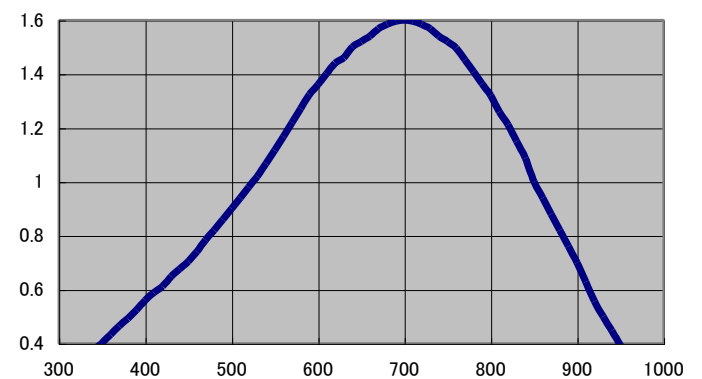

Wave Length [nm]

Contact to : Graviton Inc.

1-8-1 Kasuga-cho, IRUMA-SHI, SAITAMA, 358-0006 JAPAN

TEL : +81-4-2966-0816 FAX : +81-4-2966-0817

“GRAVITON” is trade mark of Graviton Inc. in Japan.

Copyright 2006 by Graviton Inc. All right reserved.

Never reproduce or republish without written permission.

Page 8

No. 20220831-01